

"Apollo" Valves

SUBMITTAL SHEET

70-200 Series

Solder End Bronze **Ball Valve**



Job Name:	
Job Location:	
Engineer:	
Contractor:	
Tag:	
PO Number:	
Representative:	
Wholesale Distributor:	



DESCRIPTION

The Apollo® 70 Series is the most widely used general purpose bronze ball valve on the market today. The 70-200 model is a 2-piece standard port ball valve designed to be soft soldered into lines without disassembly. Cast and machined in Apollo's South Carolina manufacturing plants, these valves provide trusted performance and a wide range of options.

FEATURES

- Premium Materials and Heavy Duty Construction
- EZ Solder Bronze
- Adjustable Stem Packing Gland
- Blow-Out Proof Stem Design
- RPTFE Seats and MPTFE Stem Packing Rings
- Chromium Plated Ball
- 100% Factory Tested
- Wide Range of Options (See Page 2)
- **Manufactured in the USA – ARRA Compliant**

APPROVALS

- MSS SP-110; Ball Valves
- CSA B51, CRN: OC10908.5C

PERFORMANCE RATING

- Maximum Pressure: 600 psi CWP
- Maximum Temperature: 500°F
- Vacuum Service to 29 in. Hg

MODELS

- 70-200 Series – Standard
- 70-240 Series – 316 SS Ball & Stem
- 70LF Series – Lead Free Option
(Refer to 70LF submittal sheet for specifications)

STANDARD MATERIALS LIST

Part Name	Material
Lever and Grip	Steel, Zinc Plated w/ Vinyl
Stem Packing	MPTFE
Stem Bearing	RPTFE
Ball	B16, Chrome Plated or B283, C37700
Seat (2)	RPTFE
Retainer	B16 or B283, C37700 (3/8" to 1"), B584-C84400 (1 1/4" to 3")
Gland Nut	B16
Stem	B16
Lever Nut	Steel, Zinc Plated
Body Seal (1 1/4" to 3")	PTFE
Body	B584-C84400

DIMENSIONS

Part Number	Size (in.)	Dimensions (in.)							Wt. (lbs.)
		A	B	C	D	E	F	G	
70-202-01	3/8"	0.37	1.28	2.56	1.75	3.87	0.51	0.37	0.63
70-203-01	1/2"	0.50	1.43	2.87	1.75	3.87	0.63	0.50	0.71
70-204-01	3/4"	0.68	1.93	3.87	2.12	4.87	0.88	0.75	1.44
70-205-01	1"	0.87	2.25	4.50	2.25	4.87	1.13	0.90	1.91
70-206-01	1-1/4"	1.00	2.31	4.62	2.62	5.50	1.38	0.96	2.95
70-207-01	1-1/2"	1.25	2.62	5.25	3.06	8.00	1.63	1.09	3.99
70-208-01	2"	1.50	3.18	6.37	3.25	8.00	2.13	1.34	5.71
70-209-01A	2-1/2"	2.00	3.74	7.51	3.72	8.00	2.63	1.48	15.53
70-200-01	3"	2.50	4.12	8.25	4.12	8.00	3.13	1.67	16.74
70-20A-01	4"	3.13	5.65	10.26	5.22	9.94	4.13	2.16	27.93

Sizes 3/8" and 1/2" are full port designs

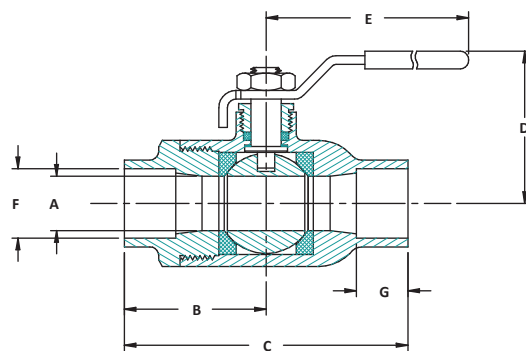

Apollo Valves, Manufactured by **Conbraco Industries, Inc.**
701 Matthews Mint-Hill Road, Matthews, NC 28105 USA
www.apollovalves.com | (704) 841-6000

This specification is provided for reference only. Conbraco Industries Inc. reserves the right to change any portion of this specification without notice and without incurring obligation to make such changes to Conbraco products previously or subsequently sold. Please visit our website @ www.apollovalves.com for the most current information.



— "Apollo" Valves —

SUBMITTAL SHEET

70-200 Series

Solder End Bronze **Ball Valve**

OPTIONS & SIZES

- (-02) Stem Grounded 3/8" - 4"
- (-04) 2 1/4" CS Stem Extension 3/8" - 3"
- (-05) Plain Ball 3/8" - 3"
- (-07) Steel Tee Handle 3/8" - 2"
- (-08) 90° Reversed Stem 3/8" - 3"
- (-10) SS Lever & Nut 3/8" - 3"
- (-11) Therma-Seal™ Insulating Tee Handle 3/8" - 2"
- (-14) Side Vented Ball (Uni-Directional) 3/8" - 4"
- (-15) Wheel Handle, Steel 3/8" - 2"
- (-16) Chain Lever - Vertical 3/8" - 2"
- (-24) Graphite Packing 3/8" - 3"
- (-27) SS Latch-Lck Lever & Nut 3/8" - 3"
- (-32) SS Tee Handle & Nut 3/8" - 2"
- (-35) VTFE Trim 3/8" - 3"
- (-39) SS Hi-Rise Locking Wheel Handle & Nut 3/8" - 2"
- (-45) Less Lever & Nut 3/8" - 3"
- (-46) Latch Lock Lever - Lock in Closed
Position Only 3/8" - 3"
- (-47) SS Oval Latch-Lock Handle & Nut 3/8" - 1"
- (-48) SS Oval Handle (No Latch) & Nut 3/8" - 2"
- (-49) Assembled Dry 3/8" - 4"
- (-50) 2-1/4" CS Locking Stem Extension 3/8" - 3"
- (-56) MPTFE Seats and Packing 3/8" - 3"
- (-57) Oxygen Cleaned 3/8" - 4"
- (-58) Chain Lever - Horizontal 3/8" - 2"
- (-60) Static Grounded Ball & Stem 3/8" - 3"
- (-63) NPT x Solder 3/8" - 4"
- (-92) Balancing Stop 3/8" - 3"
- (-94) 2-1/4" Stem Extension & Balancing Stop 3/8" - 3"
- (-HC) Hose Thread w./ Cap & Chain 1/2" - 1"

Apollo Valves, Manufactured by **Conbraco Industries, Inc.**
701 Matthews Mint-Hill Road, Matthews, NC 28105 USA
www.apollovalves.com | (704) 841-6000