

HYGROLOG HL-NT



THE INTELLIGENT DATA LOGGER.

INTRODUCING AIRCHIP DIGITAL TECHNOLOGY.

INNOVATION IN HUMIDITY AND TEMPERATURE MEASUREMENT

- FDA CFR 21 Part 11 / GAMP 4 compliance
- Outstanding accuracy and long-term stability
- Unlimited memory with Flash Card
- Display of measured values
- Interchangeable sensors for humidity and temperature
- Large range of probes
- User-friendly, validated HW4 software



SPECIFY THE BEST: HYGROLOG ADVANTAGES AT A GLANCE.

The HygroLog NT series is the latest development in data loggers for relative humidity, temperature and dew point. Thanks to the precision of the new AirChip3000 technology on which they are based, the instruments achieve a degree of accuracy not seen before .

The new HygroLog NT series not only fulfils all FDA and GAMP requirements, but also supports users in validation. With a storage capacity of more than 47,000 data points, the loggers have a virtually unlimited memory. Measurement losses are ruled out by the digital communication interface between the HygroClip2 probe and the loggers.

Flexible choice of probe

- Can use all HygroClip2-compatible probes
- HygroLog HL-NT3 with possibility to connect two additional external probes
- Probes changed in just seconds

Functional display

- Display of data on a clear, backlit graphic display with trend indicator
- Optional display and keyboard for measurement display, status display, operation, adjustment and view of logged data

FDA CFR 21 Part 11 and GAMP4 compliance

- Recording of all events such as battery changes, user actions and memory-card changes

Optional docking station

- Can be used as lockable mechanical holder
- Possible to connect four additional probes
- Monitoring of the digital switch inputs



TECHNOLOGY

AirChip3000

- Compensates humidity and temperature over 30,000 reference points
- 2,000 data point memory
- Dew/frost point calculation
- Sensor auto-diagnostics and automatic correction
- Active alarming and information
- ASIC (Application Specific Integrated Circuit), micro-controller and EEPROM on one chip

APPLICATIONS.

The data loggers in the HL-NT series are ideal for all application where data and events need to be tracked precisely (GAMP or FDA), e.g. the food and pharmaceutical industries, printing and paper industries, meteorology, agricultural sector, archaeology, climatology, etc. There is hardly a field today in which these parameters may be ignored.

HygroLog HL-NT2

Logger for interchangeable probe



HygroLog HL-NT3

Logger for interchangeable probe as well as two external sensors



Range of different docking stations

Please find the product overview at www.rotronic.com



PROBES FOR HYGROLOG HL-NT.

Whether you need a simple climate probe for measuring ambient conditions or a more sophisticated cable probe for high temperature and other special applications, we can provide you with the ideal HygroClip2 probe to suit your requirements. All HygroClip2 probes can be individually calibrated and adjusted to increase measurement precision where you need it the most. This capability is what makes every probe in the product range a high-end solution for your application.

Standard climate probes

Probes with maximum accuracy, for all climatic measurements, operating range -50...100 °C, 0...100 %rh



High temperature probes

Hand-held probes for applications to 200 °C
Probe length 250 and 400 mm Ø15 mm



Miniature probes

4 and 5 mm probes for measurements in confined spaces such as packaging etc. and for building material tests



Industrial probe

For fixed mounting
Operating range 0...100 %rh, -100...200 °C / 0...400 bar



An up-to-date overview of our extensive range of accessories such as cables, filters, sets, software and calibration equipment as well as further information on the HygroLog is available on our web site www.rotronic.com.

TECHNICAL INFORMATION.

Data logging.

Keep track of the past. The stored values can be displayed graphically with the optional HW4 software. You can define the saving intervals, alarm limits, type of alarm and much more yourself, meaning the HygroLog can be integrated in any application you like.

Adjustment.

There are three different adjustment profiles for measurement accuracy available as options. With the top version the instrument is adjusted at 20 humidity values and three different temperatures. A further advantage of this version: the data are stored on the AirChip and can therefore be used for audits.

Sensor diagnostics.

The intelligence of AirChip3000 technology enables advanced sensor diagnostics. Should the sensors deviate from factory defined parameters, the measured values are compensated electronically. You can select whether the values are to be compensated and whether an alarm is to be given.

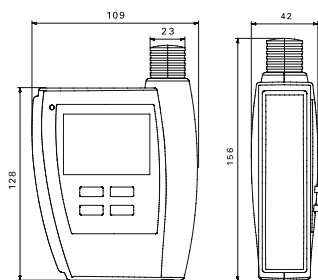

HygroLog HL-NT

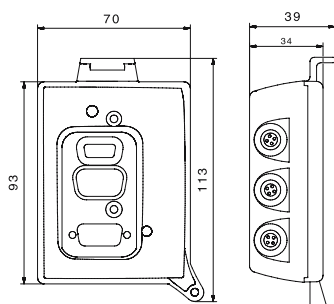

Docking stations

Logger	HygroLog HL-NT2	HygroLog HL-NT3
Humidity / Temperature sensor	ROTRONIC HygroClip2 series	
Probe inputs in the HygroLog	1	3
Probe inputs in the docking station	4	
Electronics operating range		
Humidity	0...100 %rh	
Temperature	-30...70 °C, with display -10...60 °C	
Operating range		
With alkaline battery	-10...50 °C (standard battery)	
With lithium battery	-30...70 °C	
Measurement range	Depends on probe, max. -100...200 °C	
Accuracy at 23°C with integrated HC2-S standard probe	Max. ±1.5 %rh / 0.2 K with SCS certificate	
Probes	HygroClip2 & Pt100 probes (docking station)	
Data saving interval	5 seconds to 24 hours	
Memory mode	Start/Stop/Continuous/Text with timestamp	
Alarm indicators	Visual indicators (LED, two-color) and beeper	
Logger dimensions	156 x 109 x 42 mm	
Housing material	ABS	
Probe protection	Protective cap and probe-specific filter	
Power supply (recommended)	9 V battery ≥ 500 mAh or externally via docking station	
Battery life	>1 year (with 1 HygroClip2 probe, 15 min. data saving interval, without display)	
Display (optional)	LCD full graphic display	
Logger weight	Approx. 300 g	
Data storage		
Storage medium	32 MB Flash Card (up to 1 GB possible)	
Storage capacity in text mode	With 32 MB Flash Card 800.000 data points	
Storage capacity in protected mode	With 32 MB Flash Card 1.504.000 data points	
Functions		
Event logging	All user actions, alarms, programming	
Audit trail	Full FDA CFR 21 Part 11 / GAMP4 compliance	
Adjustment	Probe adjustment in instrument possible	
Access to instrument (PC)	Via docking station	
Docking stations		
Connections	AC adapter, RS232, RS485, USB via docking station (depending on model)	
IP protection / Anti-theft device	IP65 / Integrated in docking station	
Dimensions/Weight	113 x 70 x 39 mm, ca. 175 g / NT-Desk 145 x 140 x 125 mm, ca. 350 g	
System requirements HW4 (minimum requirements)		
Processor	Pentium 1 GHz	
RAM	512 MB	
Monitor	SVGA, 1027 x 768, 256 colours, 96 DPI	
Harddisk	HW4: 50 MB / NET2: 280 MB	
Operating system	Windows XP Service Pack 2, Windows 2000 Service Pack 3, Windows Server 2003, Windows Vista	
Software	Standard: HW4-E / Professional: HW4-P	

Subject to technical change without notice. Errors and omissions excepted.

Change over now to the HygroClip2 probes with integrated AirChip3000 technology for your temperature and humidity measurements. You can find detailed information about our probes at



HANLEY CONTROLS
CLONMEL

www.hccl.ie

rotronic
MEASUREMENT SOLUTIONS